

Owenby

THE ASHFORD

2-3 Bedrooms | 2 Bathrooms | 2-Car Garage | 2,022+ Square Feet



STANDARD FEATURES:

Elegant 2 Bedroom | 2 Bath Ranch Home | Study
Second Floor Attic Storage Accessed by Permanent Stairs
Owner's Suite with Luxurious Bath and Walk-in Shower with Bench Seat
Island Kitchen Opens to Dining and Great Room
Private Covered Porch and Fenced Courtyard Retreat

A 55 OR BETTER COMMUNITY FROM THE MID \$500s

200 Beckton Circle | Woodstock, GA 30188 | 770.917.8082 | WindsongLife.com

7.8.22



All illustrations, specifications, pricing and details are believed correct at the time of publication, Windsong Properties reserves the right to make changes, without notice or obligation. This brochure is for illustrative purposes only and not part of a legal contract. Information subject to changes, errors and omissions. Owenby is a community designed for residents aged 55 and older. © 2021 Windsong Properties



THE ASHFORD



ELEVATION A



ELEVATION B



ELEVATION C

Shutters are pre-determined per plan and are not optional.
Brick homes receive raised panel shutters, per plan.
Stone homes receive board and batten shutters, per plan.

THE ASHFORD

2-3 Bedrooms | 2 Bathrooms | 2-Car Garage | 2,022+ Square Feet

**ADDS
208 Sq. Ft.**

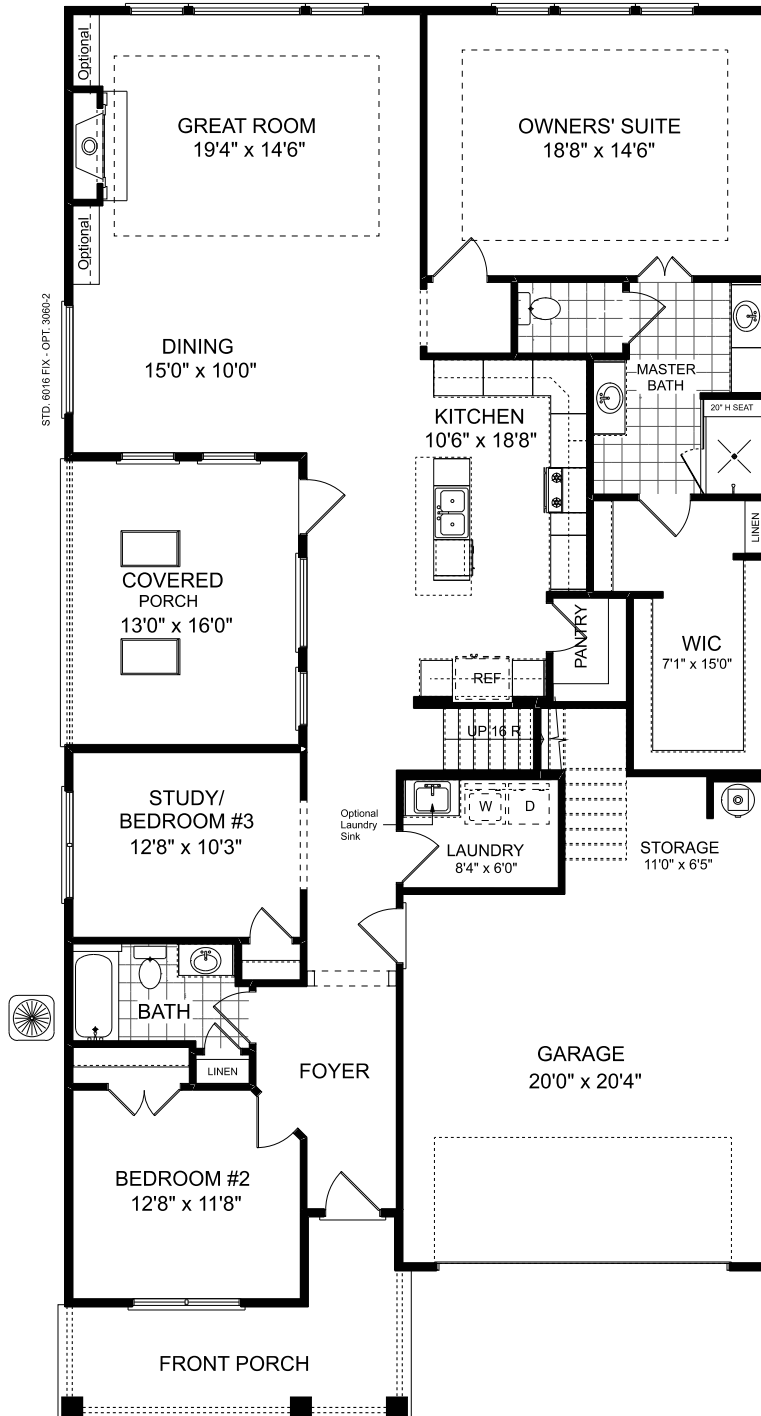
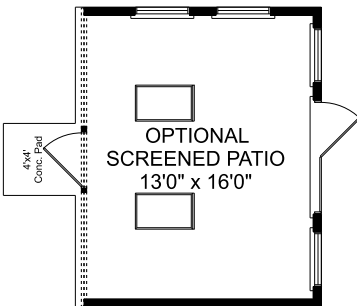
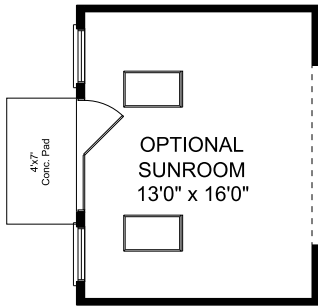

Optional
Boxed Bay Window

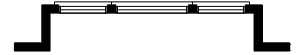

Optional
Bay Window

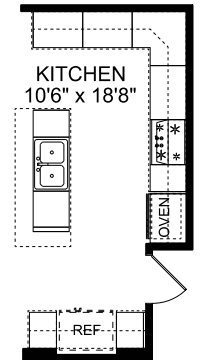

Optional
Gourmet Kitchen

Owenby

THE ASHFORD attic storage

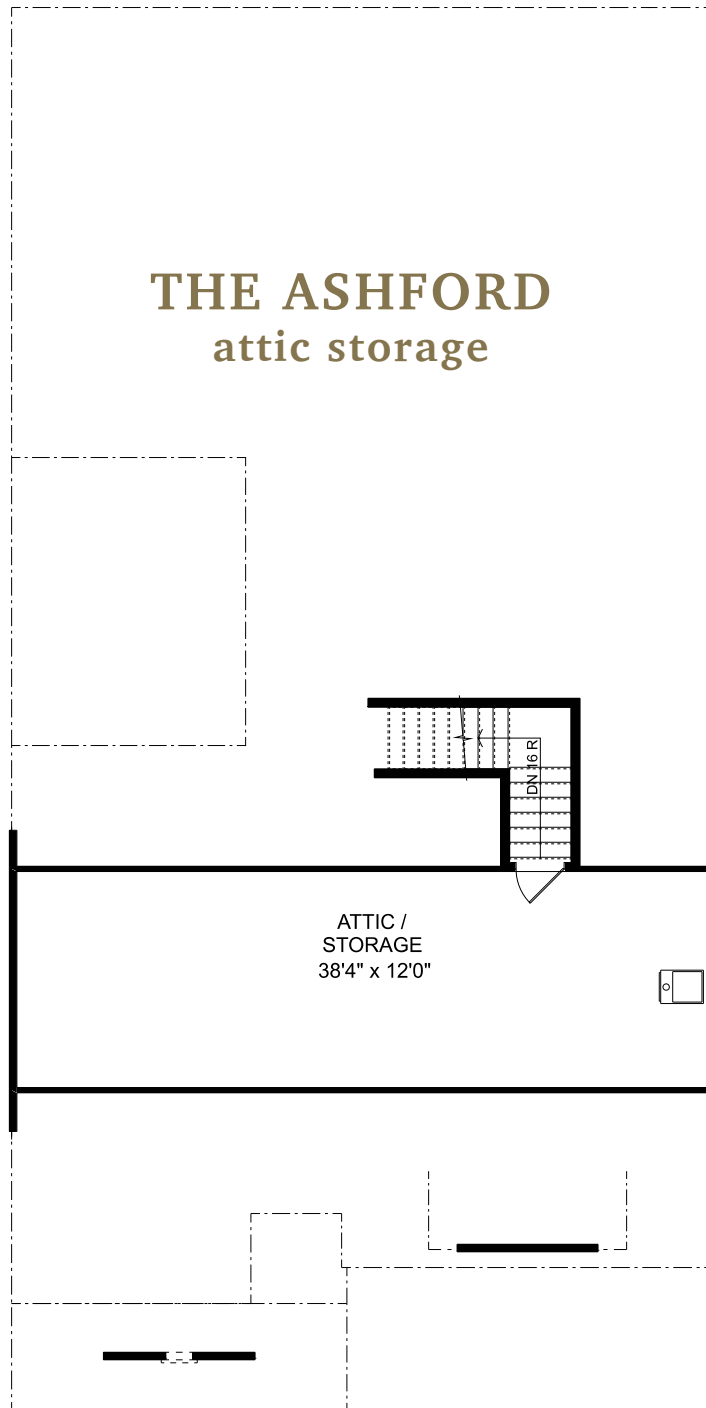

Owenby

THE ASHFORD WITH BONUS

2-4 Bedrooms | 3 Bathrooms | 2-Car Garage | 2,434+ Square Feet



STANDARD FEATURES:

Elegant 3 Bedroom | 3 Bath Ranch Home | Study
Second Floor Bonus/3rd Bedroom, Full Bath and Storage Room
Owner's Suite with Luxurious Bath and Walk-in Shower with Bench Seat
Island Kitchen Opens to Dining and Great Room
Private Covered Porch and Fenced Courtyard Retreat

A 55 OR BETTER COMMUNITY FROM THE MID \$500s

200 Beckton Circle | Woodstock, GA 30188 | 770.917.8082 | WindsongLife.com

7.8.22



All illustrations, specifications, pricing and details are believed correct at the time of publication, Windsong Properties reserves the right to make changes, without notice or obligation. This brochure is for illustrative purposes only and not part of a legal contract. Information subject to changes, errors and omissions. Owenby is a community designed for residents aged 55 and older. © 2021 Windsong Properties



THE ASHFORD WITH BONUS



ELEVATION A



ELEVATION B



ELEVATION C

Shutters are pre-determined per plan and are not optional.
Brick homes receive raised panel shutters, per plan.
Stone homes receive board and batten shutters, per plan.

THE ASHFORD WITH BONUS

2-4 Bedrooms | 3 Bathrooms | 2-Car Garage | 2,434+ Square Feet

**ADDS
208 Sq. Ft.**

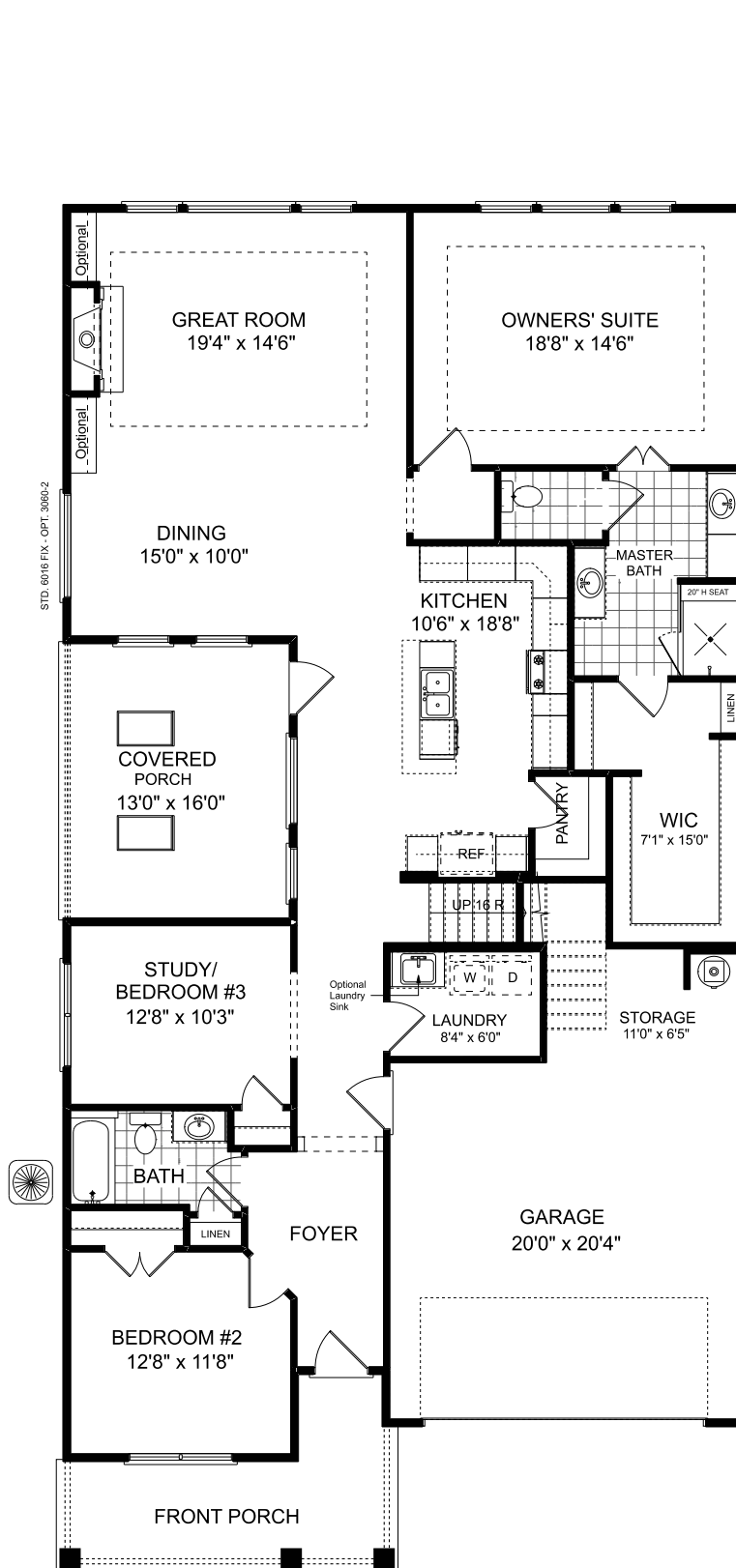
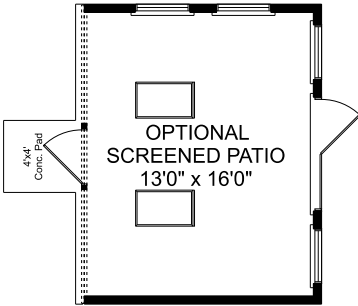
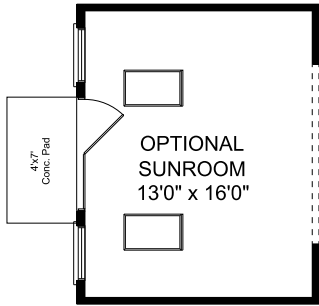

Optional
Boxed Bay Window



Optional
Bay Window

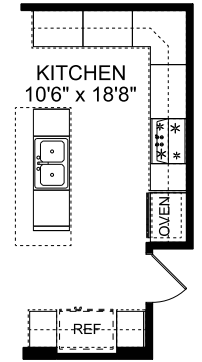

Optional
Gourmet Kitchen

Owenby

THE ASHFORD with Bonus

